

4차 산업혁명과 사물인터넷

(사물인터넷, 과거, 현재 그리고 미래)

제3강

우 송 대 학 교
철도 전기시스템학과
최 상 성

사물인터넷(IoT)이란 무엇인가?



[사물 인터넷이란 무엇인가?]

사물인터넷(Internet of Things: IoT)

- 모든 사물과 사람을 연결해 상호 소통하는 **지능형 기술 서비스**

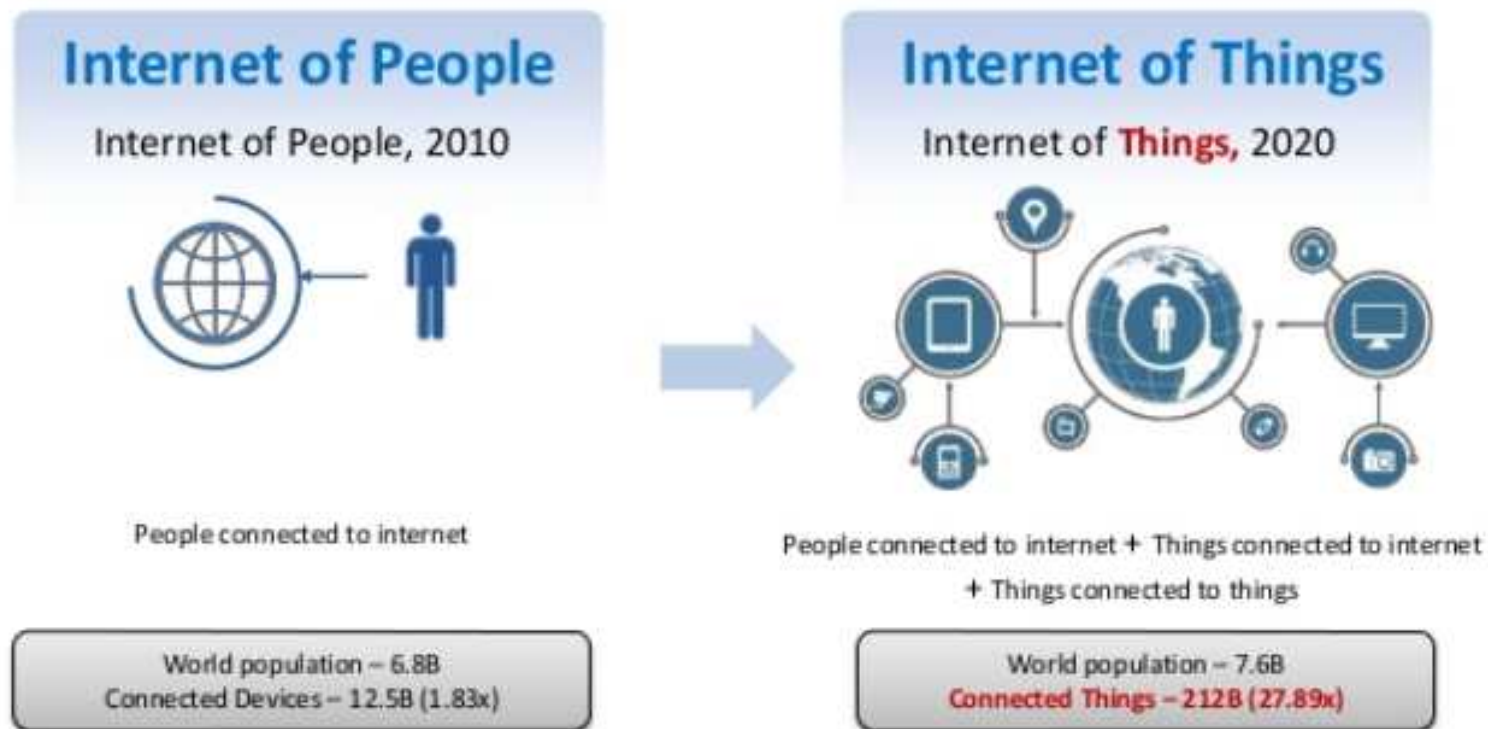

사물인터넷 역사(1/12)

▪ 1926 Nikola Tesla

Interview with Colliers magazine

When wireless is perfectly applied, the whole earth will be converted into a huge brain. ...

the instruments through which we shall be able to do this will be amazingly simple compared with our present telephone. A man will be able to carry one in his vest pocket.



[Nikola Tesla]

▪ 1950 Alan Turing

Computing Machinery and Intelligence

It is best to provide the machine with the best sense organs ..., and then teach it to understand and speak English. This process could follow the normal teaching of a child.



[Alan Turing]

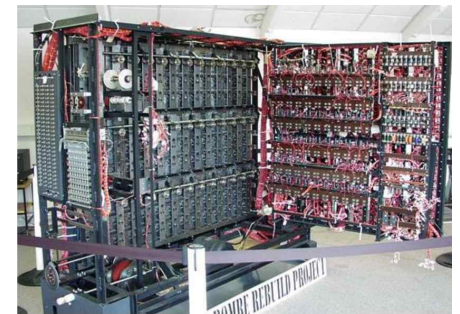

[튜링 볼배 : 암호 해독기]

사물인터넷 역사(2/12)

- **1964 Marshall McLuhan**

 - Understanding Media**

 - ...by means of electric media, we set up a dynamic by which all previous technologies -- including cities -- will be translated into information systems*

- **1966 Karl Steinbuch**

 - The Information Society**

 - In a few decades time, computers will be interwoven into almost every industrial product.*



[Marshall McLuhan]



[Karl Steinbuch]

사물인터넷 역사(3/12)

- 1968 Arpanet**
Advanced Research Projects Agency Network

ARPANET, in full Advanced Research Projects Agency Network, experimental computer network that was the forerunner of the Internet.

- 1974 TCP/IP**
Transmission Control Protocol/Internet Protocol

TCP/IP, or the Transmission Control Protocol/Internet Protocol, is a suite of communication protocols used to interconnect network devices on the internet.

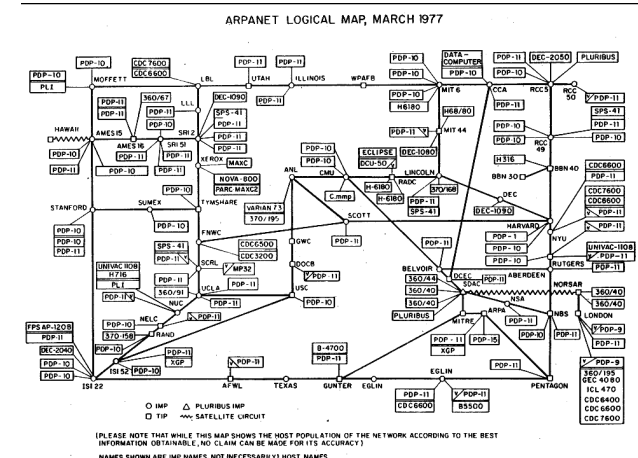

[Arpanet 논리 지도]

출처: 위키백과

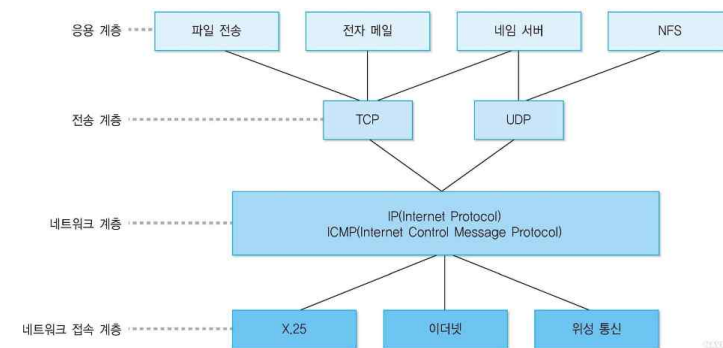

[TCP/IP 구조]

출처: 지식백과

사물인터넷 역사(4/12)

- **1982 Carnegie-Mellon University**
Internet Coke Vending Machine

It was connect to the internet to check how many bottles were in the machine and whether they were cold or not.



The First Internet Coke Machine
@ Dept. of Computer Science,
Carnegie Mellon University



To solve the "warm Coke problem"

command : coke
protocol : Coke@+™

사물인터넷 역사(5/12)

■ 1984 DNS

Domain Name System

The Domain Name System (DNS) is a hierarchical decentralized naming system for computers, services, or other resources connected to the internet or a private network.



[Domain Name System]

■ 1989 WWW

World Wide Web

The World Wide Web (abbreviated WWW or the Web) is an information space where documents and other web resources are identified by Uniform Resource Locators (URLs), interlinked by hypertext links, and can be accessed via the Internet.



[세계 최초 World Wide Web]

사물인터넷 역사(6/12)

- 1990 John Romkey

 - Internet Toaster**

 - The toaster was connected to a computer with TCP/IP networking to turn on and off over the Internet.*

- 1990 Olivetti

 - Active badge system**

 - using infrared signals to communicate a person's location*



[John Romkey Internet Toaster 설명]

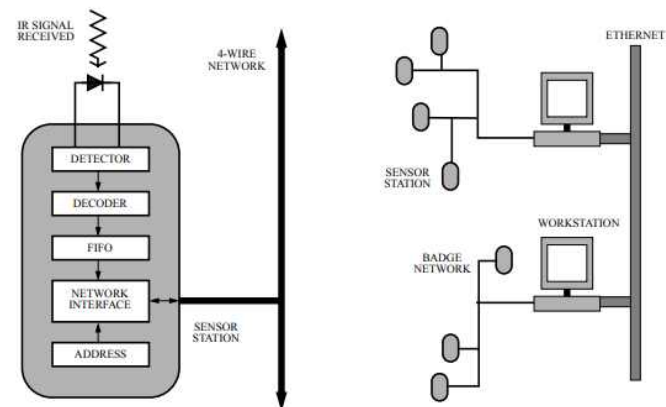

[Badge Sensor and Telemetry Network]

출처: Olivetti Research Ltd

사물인터넷 역사(7/12)

- **1991 Mark Weiser**
The Computer in the 21st Century
Ubiquitous Computing
The most profound technologies are those that disappear. They weave themselves into the fabric of everyday life until they are indistinguishable from it



[Trojan Room Coffee Pot]

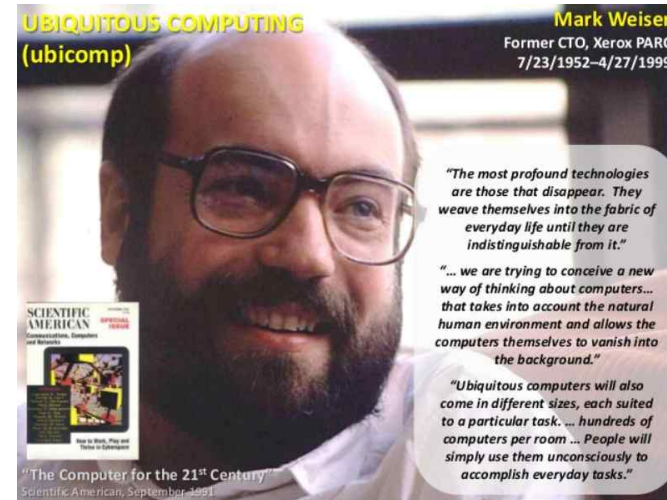

[Mark Weiser]

출처: Gerson Lehrman Group

- **1993 University of Cambridge**
Trojan Room Coffee Pot
It was used to monitor the pot levels with an image being updated about 3x a minute and sent to the buildings server.

사물인터넷 역사(8/12)

- 1998 Ishii, MIT

 - inTouch**

 - We present inTouch ...to create a "tangible telephone" for long distance haptic communication.*

- 1991 RFID-EPC/USN

 - Auto-ID Labs, MIT**

 - In the 20th century, computers were brains without senses - they only knew what we told them.*

 - In the 21th century, because of the internet of things, computers can sense things for themselves.*



[tangible telephone]



[Bar Code & RFID]

사물인터넷 역사(9/12)

▪ 사물인터넷 용어 등장

요즘 자주 회자하는 사물인터넷(Internet of Things)이라는 용어의 탄생은 1999년으로 거슬러 올라간다.

인터넷(Internet)이 탄생한 지 정확히 30년 후의 일이다.

당시 비누, 샴푸, 칫솔 등 다양한 종류의 소비재를 제조 및 판매했던 P&G에서 브랜드 매니저로 근무하던 케빈 애시턴(Kevin Ashton)이 이 용어를 처음으로 사용하였는데,

자사의 제품들에 RFID 태그를 부착함으로써 제품들의 가시성을 확보할 수 있는 것처럼 세상에 존재하는 모든 사물이 서로 연결될 수 있다면 새로운 세상이 펼쳐질 것이라는 생각에서 기인했다.



[Kevin Ashton]

출처: 과학학습콘텐츠 사물인터넷

사물인터넷 역사(10/12)

- 1999 Neil Gershenfeld, MIT

- When Things Start to Think**

- in retrospect it looks like the rapid growth of the World Wide Web may have been just the trigger charge that is now setting off the real explosion, as things start to use the Net.*



[the Future of Digital Fabrication]

사물인터넷 역사(11/12)

- 2001~ PoC(Proof of Concept) Projects
HP Cooltown, MIT Internet 0, MIT Oxygen, CMU ARA,
EU Disappearing Computer Initiative.



[HP Cooltown]

사물인터넷 역사(12/12)

- **2005 ITU**

- ITU Report**

- The United Nations first mentions IoT in International Telecommunications Union report. Three years later, the first international IoT conference takes place in Zurich, 2008*

- **2006 The 1st European IOT conference**

- **2008 IPSO Alliance launched,**

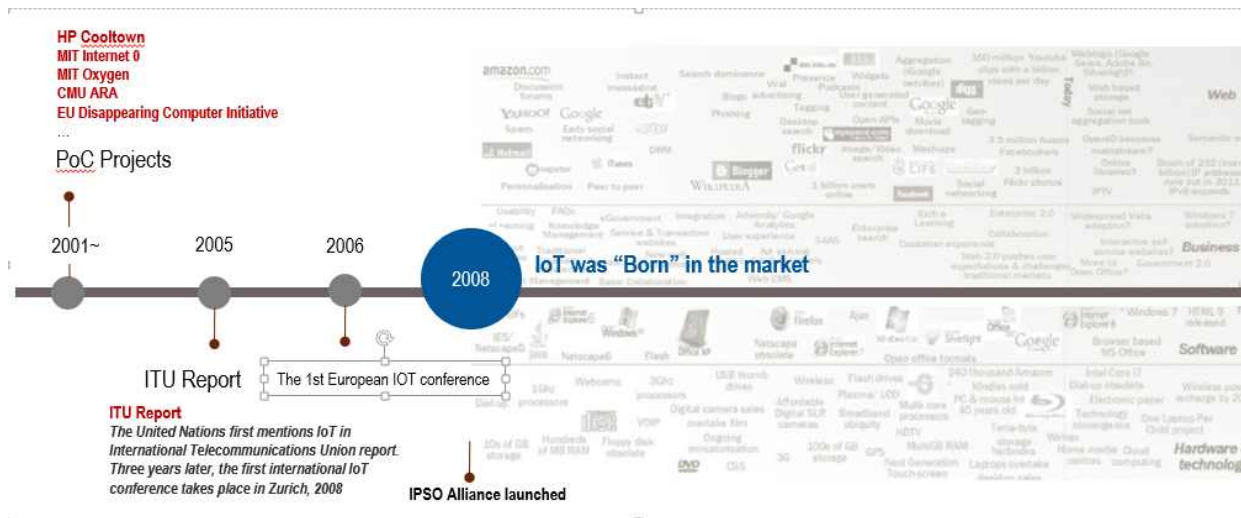

사물인터넷 현황(1/7)

<p>스마트 워터 시스템 (카타르, 브라질, 중국 등)</p>	<p>상하수도 시스템에 센서 설치 → 40~50%의 누수 방지</p>	
<p>쓰레기 관리시스템 (신사네티)</p>	<p>가정 쓰레기 배출량 모니터링 → 쓰레기 배출량 17% 감소 및 재활용 49% 증가</p>	
<p>지능형 운영센터 운영 (브라질)</p>	<p>기상데이터 분석을 폭우 가능성 예측 → 대응시간 약 30% 개선, 사망자수 10% 감소</p>	
<p>지능형 교통시스템 (영국)</p>	<p>고속도로 지능형교통 시스템 구축 → 통행시간 25% 단축 및 교통사고 50% 감소</p>	

출처: 미래부 사물 인터넷 기본계획 2014년

사물인터넷 현황(2/7)

<p>스마트 가로등 (바로셀로나)</p>	<p>가로등에 센서설치 및 자동 조명 세기 조절 → 연간 30% 에너지 절감</p>	
<p>GPS/센서 농축산업 적용</p>	<p>GPS 활용 파종한 라인 제어 → 트랙터 작업 효율을 20% 개선</p>	
<p>제조업의 서비스화 (롤스로이스)</p>	<p>제품의 서비스화(10% → 50%) → 영업이익률 2.5배 증가</p>	
<p>스마트약병 서비스</p>	<p>약 뚜껑 센서 부착 및 투약 시점관련 정보 제공 → 98% 이상의 복약 이행</p>	

출처: 미래부 사물인터넷 기본계획 2014년

사물인터넷 현황(3/7)

<p>Babble (한국, 모뉴엘)</p>		<p>청각장애 부모 아이 돌봄 장치</p>
<p>스마트화분 (한국, nThing)</p>		<p>스마트 화분에서 물, 빛 등이 식물성장 관리 * KETI에서 개발한 개방형 플랫폼 기술 적용</p>
<p>에이스캔 (한국, 에이스엔)</p>		<p>입김만으로 알코올 농도 파악</p>

사물인터넷 현황(4/7)

라이프밴드터치
(한국, LG전자)



사용자 신체활동량 측정 손목밴드

커넥티드 자전거
(한국, 삼성전자)



자전거의 주행속도, 운행거리
및 자신의 운동량 등 파악

유린케어
(한국, 아이티헬스)



스마트폰 기반의 대·소변 관리
시스템

사물인터넷 현황(5/7)

<p>Pebble (독일, 벤츠)</p>		<p>차량 주차 위치, 도어 잠김 여부, 주유 상태 등 파악</p>
<p>i 리모트 (독일, BMW)</p>	 <p>BMW i3 + Samsung GALAXY Gear</p>	<p>차량 상태 확인 및 잠금 등 원격 제어</p>
<p>테니스 센서 (일본, 소니)</p>		<p>테니스 칠 때 움직임 분석</p>

출처: 미래부 사물인터넷 기본계획 2014년

사물인터넷 현황(6/7)

RGB Lamp
(유럽, NXP)



컬러 제어와 빛 출력제어 조명

무선 혈압 모니터
(미국, iHealth)



실시간 혈압 모니터링

해피포크
(홍콩, HAPILab)



음식 투입속도 및
포크 이용 횟수 등 측정

사물인터넷 현황(7/7)



[Life Simplified with Connected Devices]

사물인터넷 시장 동향(1/6)

글로벌 기업들은 자사의 핵심역량을 바탕으로
글로벌 생태계 주도를 위해 경쟁 중이나 아직은 지배적 사업자 부재



출처: 미래부 사물인터넷 기본계획 2014년

사물인터넷 시장 동향(2/6)

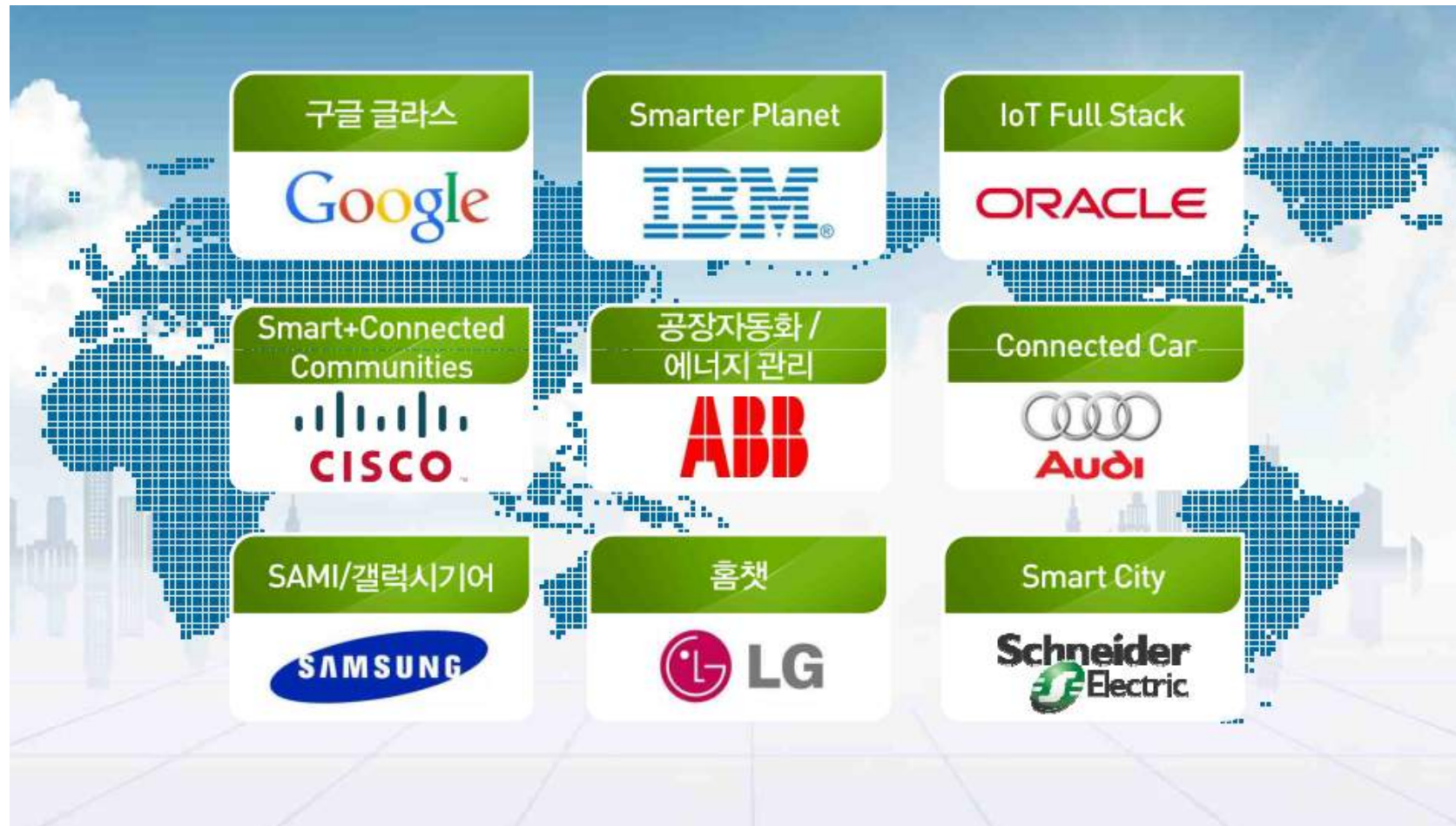

출처: 미래부 사물인터넷 기본계획 2014년

사물인터넷 시장 동향(3/6)



출처: 미래부 사물인터넷 기본계획 2014년

사물인터넷 시장 동향(4/6)



출처: 미래부 사물인터넷 기본계획 2014년

사물인터넷 시장 동향(5/6)

The image displays two panels of M&A activity in the IoT market. The left panel, titled 'DBMS, Full Stack', shows Oracle acquiring Bluekai, with a value of 4 billion for social data analysis/marketing. The right panel, titled '[UK, 3.1 billion] Semiconductor Design Company', shows CSR acquiring Samsung and Nanoradio, with a value of 3.1 billion for low-power WLAN chips.

DBMS, Full Stack

ORACLE

+ (인수)

bluekai

소셜데이터분석/마케팅 (4억불)

[영국, 3.1억불] 반도체설계회사

csr

+ (인수)

SAMSUNG

+ (인수)

nanoradio
Always on WiFi

나노라디오(스웨덴) 초저전력 WLAN 칩셋

출처: 미래부 사물인터넷 기본계획 2014년

사물인터넷 시장 동향(6/6)



출처: 미래부 사물인터넷 기본계획 2014년

사물인터넷 시장 전망

- **세계** '13년 2천억 달러 → '20년 1.2조 달러, 연평균 21.8% 성장 전망
- **국내** '13년 2.3조 원 → '20년 17.1조 원, 연평균 32.8% 성장 전망

단위: 억 달러, %

		2013	2022	CAGR
디바이스	반도체 칩(Chipsets)	58	281	19,2
	모듈(Modules)	102	477	18,7
	단말기(Terminals)	1,728	3,692	8,8
	합계	1,888	4,450	10,0
이동통신망	GSM/HSPA	31	69	9,3
	CDMA	42	78	7,1
	LTE	14	201	34,5
	기타	8	43	20,5
	합계	95	391	17,0
시스템사업자	제품기기 제조사	12	694	57,0
	시스템통합사업자	14	1,436	67,3
	특정 어플리케이션 임대사업자	8	904	69,1
	B2B/B2C 서비스 사업자	3	521	77,4
	합계	37	3,555	66,1
서비스 및 어플리케이션	자동차 텔레매틱스	5	1,492	88,4
	차량관제	1	186	78,7
	스마트그리드 및 관리	2	215	68,2
	고정형 무선통신	1	271	86,4
	생활가전	1	1,184	119,5
	기타 분야	1	204	80,6
합계	11	3,552	90,0	
총계		2,031	11,948	21,8

자료: Machina Research(2013), NIA(2013):

유형	하드웨어			소프트웨어		
	반도체칩	통신모듈	단말기	플랫폼	통신	전문서비스
	무선 송수신칩, 센서	IoT 모듈	다양한 IoT 단말기	플랫폼 SW, 관리솔루션	유무선 네트워크	전문 IoT서비스
평균 성장률	19.2%	18.3%	8.8%	66.1%	17.0%	90%

* '13~'22년 CAGR



미래 사물인터넷 발전 방향

Emergent IoT Ecosystem IoT + AI

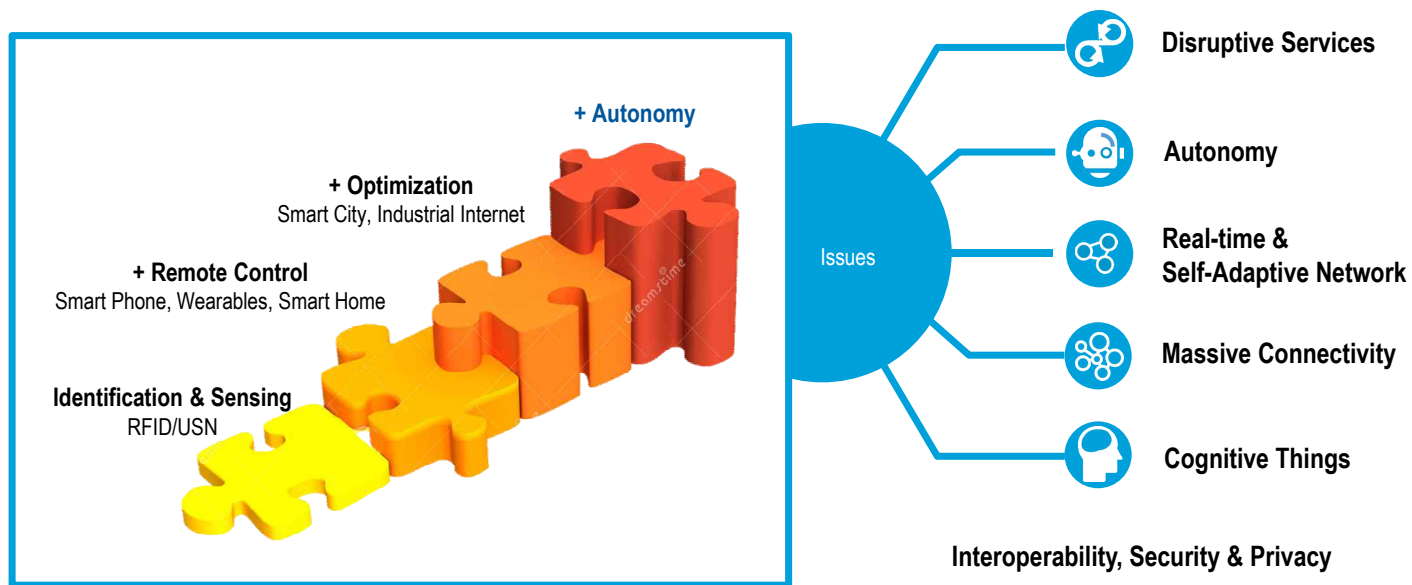

IoT Device 기술 발전 방향

Tiny Things



Robotized Things

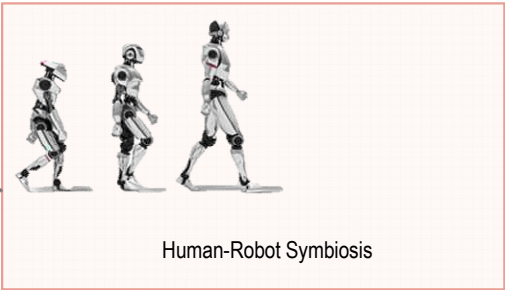

Digital Twined Things

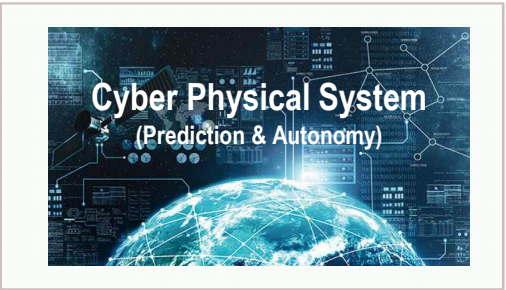
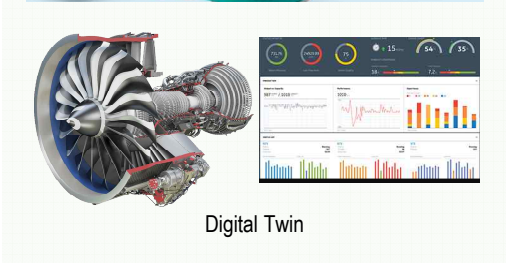

IoT Network 기술 발전 방향

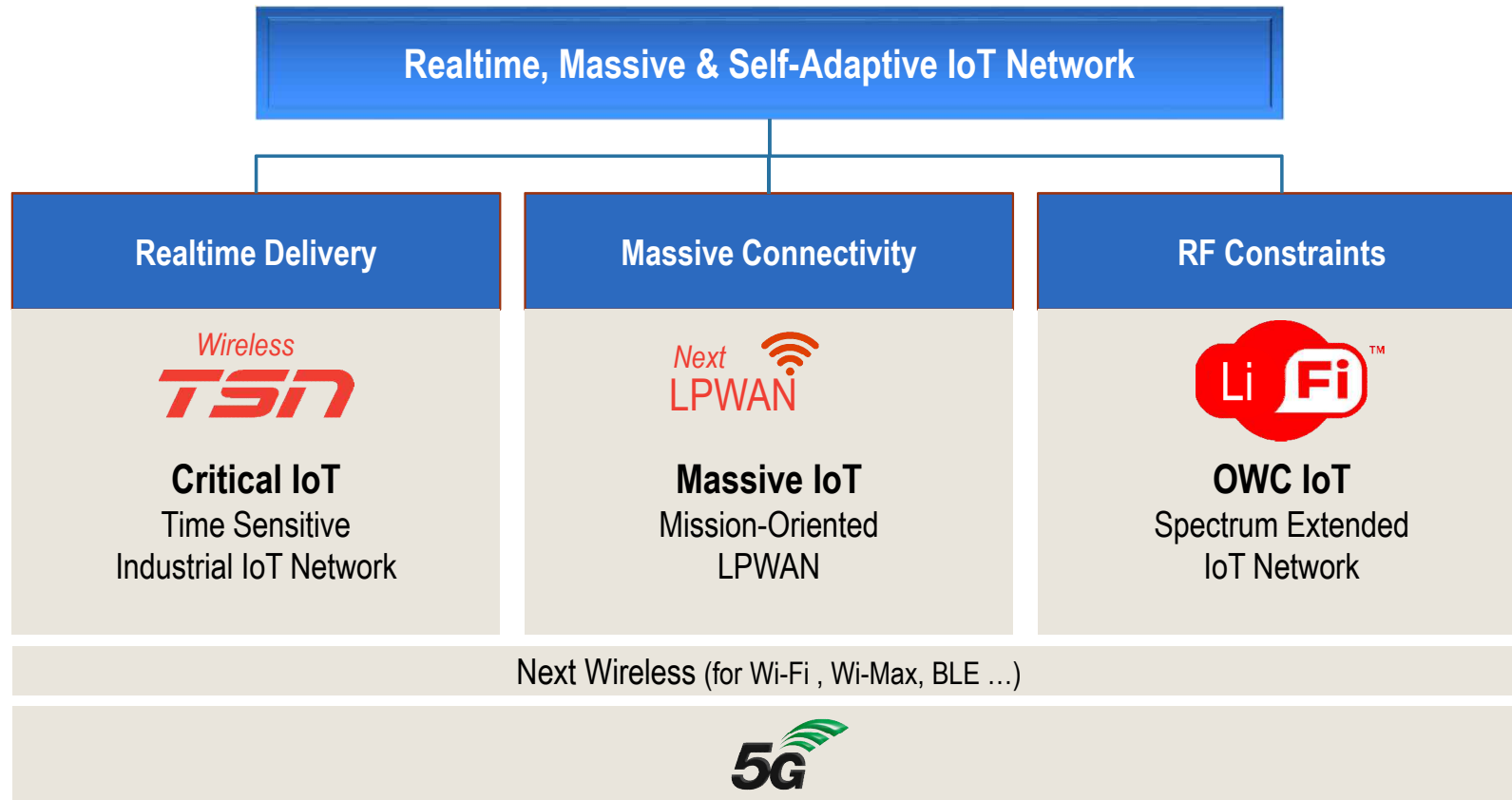

IoT Platform 기술 발전 방향

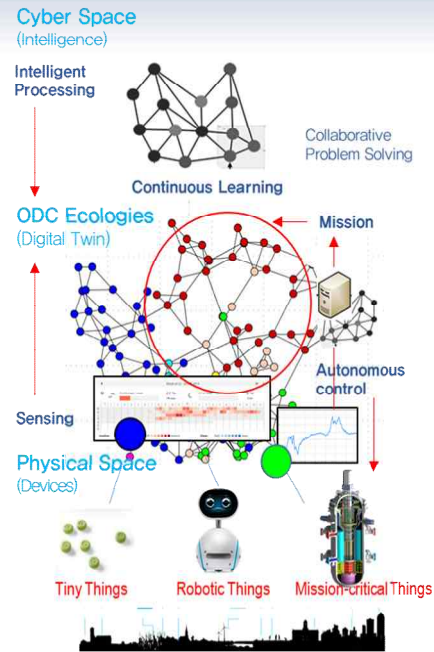
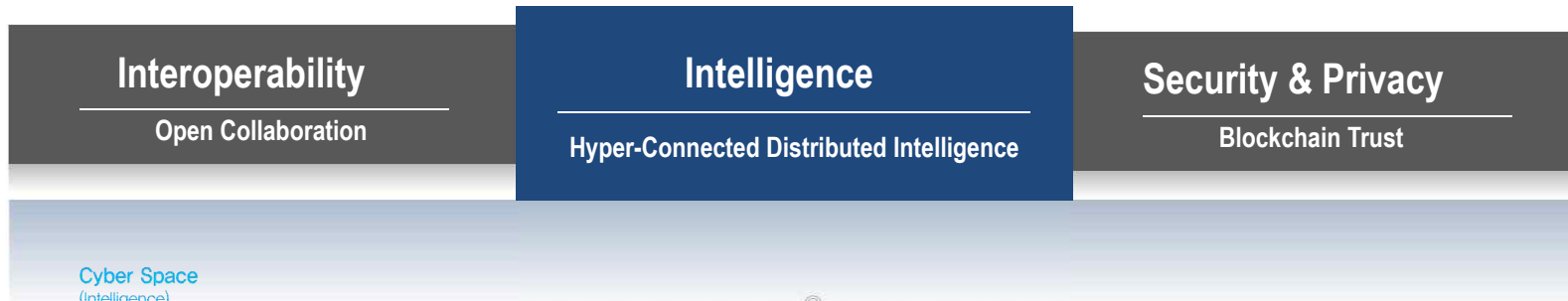

Architectural Changes: CENTRALIZED > DECENTRALIZED > DISTRIBUTED

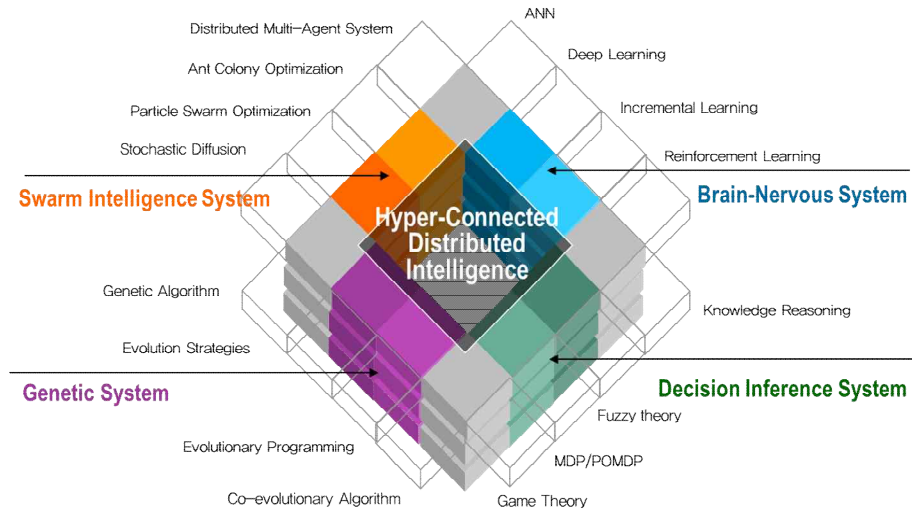

Disruptive Services

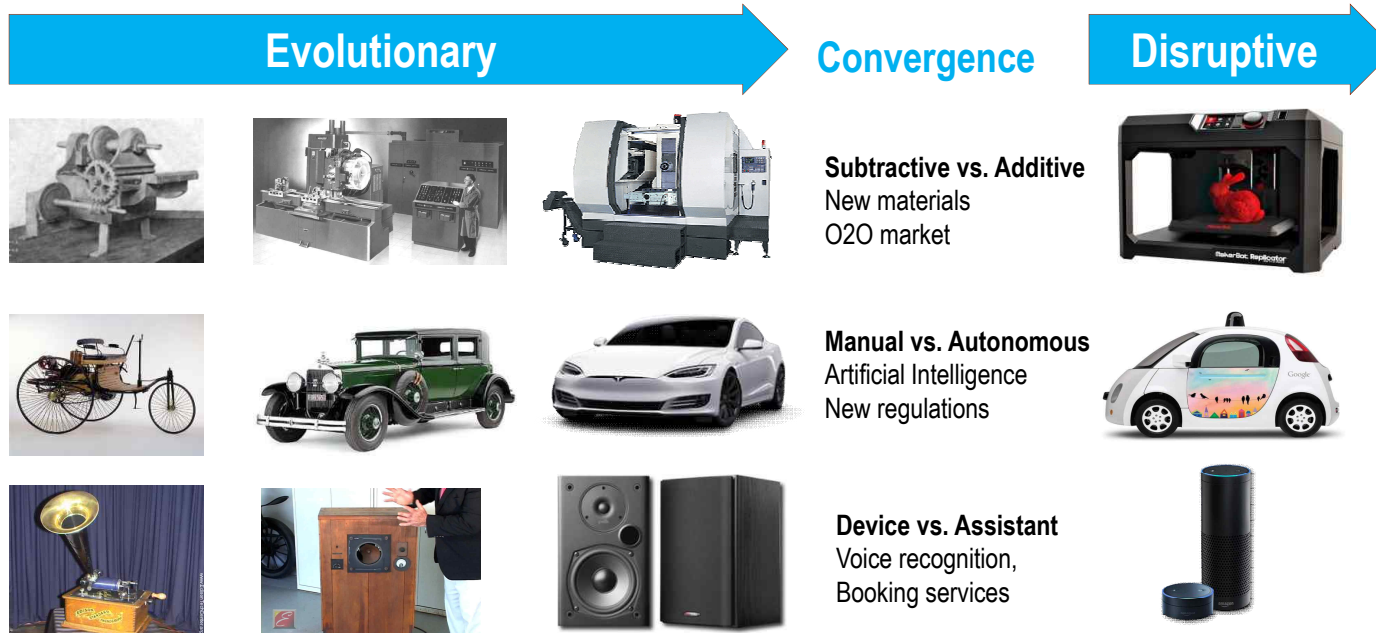

at&t

amazon

Google

Disrupt or be disrupted! Actions must be taken to avoid becoming “Ubered.” (GE)
Digital disruption will replace **40%** of today’s top incumbents within the next 5 years (CISCO)

미래 사회의 모습



[미래 사회의 모습]

결론

Beyond IoT

“Human-Thing Symbiosis and Co-evolution”

In the near future, *IoT as a Service* will be introduced.

In the future, people and things will live and evolve together.

We need to redesign a human-oriented future for human being, not machines.

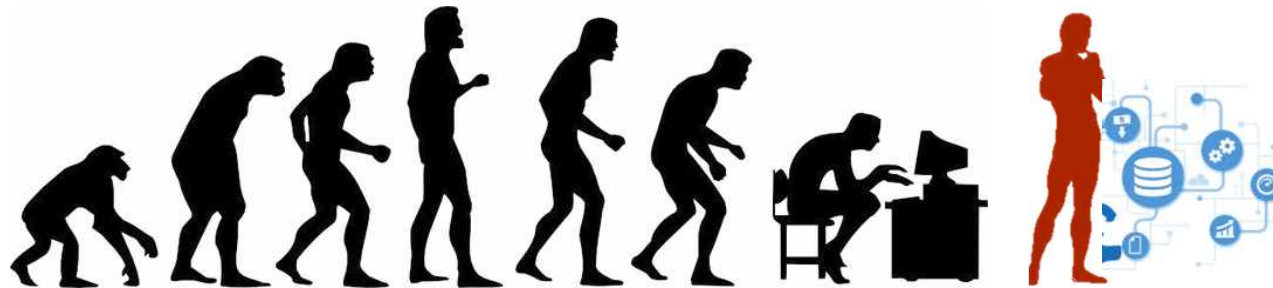

감사합니다 !



for details about this presentation, please email to sschoi@wsu.ac.kr